

E96-442

Bailey®
infi 90

Instruction

Controller/Station Termination Unit (NTCS04)

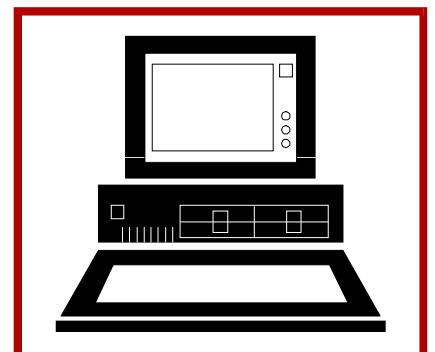
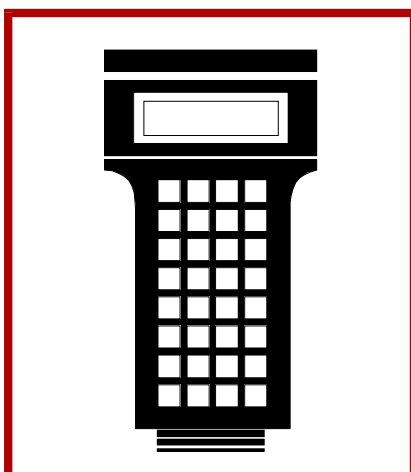
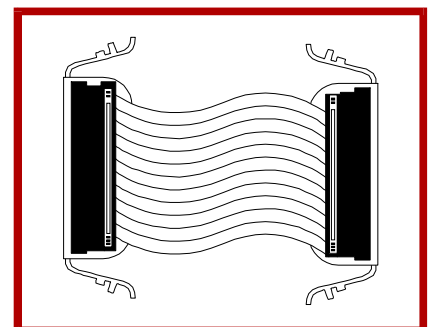
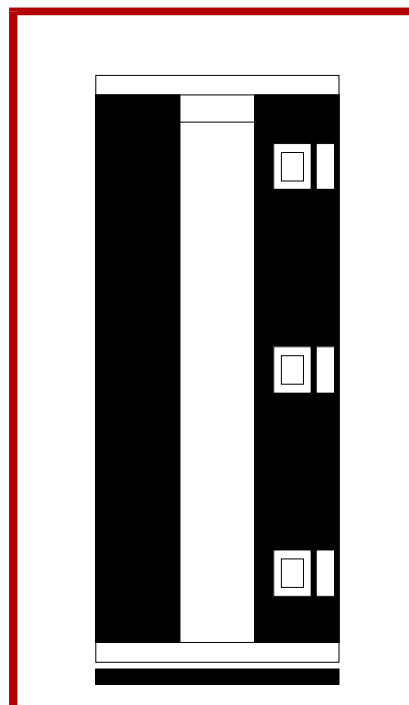
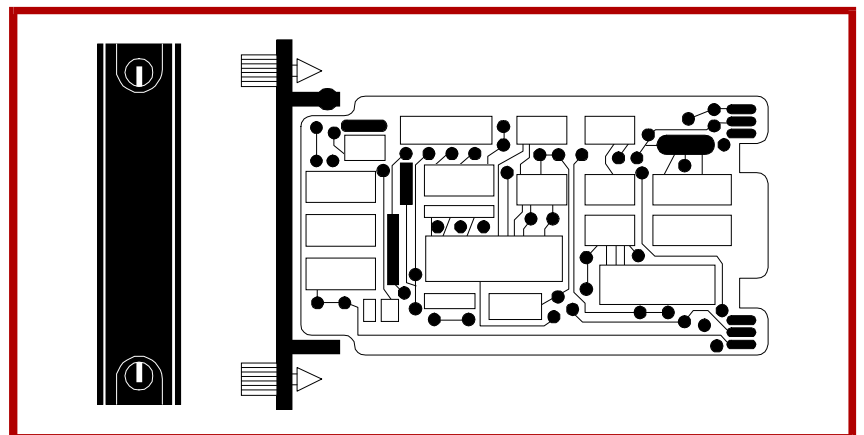
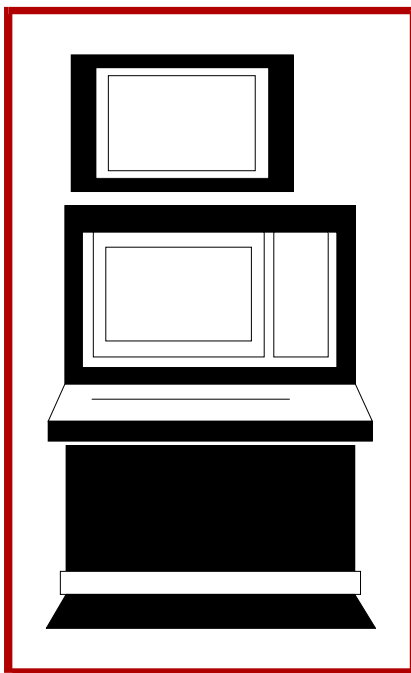

WARNING notices as used in this instruction apply to hazards or unsafe practices that could result in personal injury or death.

CAUTION notices apply to hazards or unsafe practices that could result in property damage.

NOTES highlight procedures and contain information that assists the operator in understanding the information contained in this instruction.

WARNING

INSTRUCTION MANUALS

DO NOT INSTALL, MAINTAIN, OR OPERATE THIS EQUIPMENT WITHOUT READING, UNDERSTANDING, AND FOLLOWING THE PROPER **Elsag Bailey** INSTRUCTIONS AND MANUALS; OTHERWISE, INJURY OR DAMAGE MAY RESULT.

RADIO FREQUENCY INTERFERENCE

MOST ELECTRONIC EQUIPMENT IS INFLUENCED BY RADIO FREQUENCY INTERFERENCE (RFI). CAUTION SHOULD BE EXERCISED WITH REGARD TO THE USE OF PORTABLE COMMUNICATIONS EQUIPMENT IN THE AREA AROUND SUCH EQUIPMENT. PRUDENT PRACTICE DICTATES THAT SIGNS SHOULD BE POSTED IN THE VICINITY OF THE EQUIPMENT CAUTIONING AGAINST THE USE OF PORTABLE COMMUNICATIONS EQUIPMENT.

POSSIBLE PROCESS UPSETS

MAINTENANCE MUST BE PERFORMED ONLY BY QUALIFIED PERSONNEL AND ONLY AFTER SECURING EQUIPMENT CONTROLLED BY THIS PRODUCT. ADJUSTING OR REMOVING THIS PRODUCT WHILE IT IS IN THE SYSTEM MAY UPSET THE PROCESS BEING CONTROLLED. SOME PROCESS UPSETS MAY CAUSE INJURY OR DAMAGE.

AVERTISSEMENT

MANUELS D'OPÉRATION

NE PAS METTRE EN PLACE, RÉPARER OU FAIRE FONCTIONNER L'ÉQUIPEMENT SANS AVOIR LU, COMPRIS ET SUIVI LES INSTRUCTIONS RÉGLEMENTAIRES DE **Elsag Bailey**. TOUTE NÉGLIGENCE À CET ÉGARD POURRAIT ÊTRE UNE CAUSE D'ACCIDENT OU DE DÉFAILLANCE DU MATÉRIEL.

PERTURBATIONS PAR FRÉQUENCE RADIO

LA PLUPART DES ÉQUIPEMENTS ÉLECTRONIQUES SONT SENSIBLES AUX PERTURBATIONS PAR FRÉQUENCE RADIO. DES PRÉCAUTIONS DEVRONT ÊTRE PRISES LORS DE L'UTILISATION DU MATÉRIEL DE COMMUNICATION PORTATIF. LA PRUDENCE EXIGE QUE LES PRÉCAUTIONS À PRENDRE DANS CE CAS SOIENT SIGNALÉES AUX ENDROITS VOULUS DANS VOTRE USINE.

PERTURBATIONS DU PROCÉDÉ

L'ENTRETIEN DOIT ÊTRE ASSURÉ PAR UNE PERSONNE QUALIFIÉE EN CONSIDÉRANT L'ASPECT SÉCURITAIRE DES ÉQUIPEMENTS CONTRÔLÉS PAR CE PRODUIT. L'AJUSTEMENT ET/OU L'EXTRACTION DE CE PRODUIT PEUT OCCASIONNER DES À-COUPS AU PROCÉDÉ CONTRÔLE LORSQU'IL EST INSÉRÉ DANS UNE SYSTÈME ACTIF. CES À-COUPS PEUVENT ÉGALEMENT OCCASIONNER DES BLESSURES OU DES DOMMAGES MATÉRIELS.

NOTICE

The information contained in this document is subject to change without notice.

Elsag Bailey, its affiliates, employees, and agents, and the authors and contributors to this publication specifically disclaim all liabilities and warranties, express and implied (including warranties of merchantability and fitness for a particular purpose), for the accuracy, currency, completeness, and/or reliability of the information contained herein and/or for the fitness for any particular use and/or for the performance of any material and/or equipment selected in whole or part with the user of/or in reliance upon information contained herein. Selection of materials and/or equipment is at the sole risk of the user of this publication.

This document contains proprietary information of Elsag Bailey, Elsag Bailey Process Automation, and is issued in strict confidence. Its use, or reproduction for use, for the reverse engineering, development or manufacture of hardware or software described herein is prohibited. No part of this document may be photocopied or reproduced without the prior written consent of Elsag Bailey.

Preface

The NTCS04 Termination Unit provides an interface for:

- Field wiring when IMCIS02 and IMQRS01/02 Slave Modules are used to supply analog and digital field I/O.
- Digital control stations and digital indicator stations.
- Controller Modules (IMCOM03/04). Quick Response Controllers (IMQRC01), multi-function controllers and Bailey Control PC-90[®] Processors.
- Remote I/O slave modules via their respective termination units/modules.

This product instruction explains the installation and various setups for configuring the TCS.

[®] PC-90 is a registered trademark of Elsag Bailey Process Automation.

List of Effective Pages

Total number of pages in this instruction is 29, consisting of the following:

Page No.	Change Date
Preface	Original
List of Effective Pages	Original
iii through vi	Original
1-1 through 1-4	Original
2-1 through 2-14	Original
3-1	Original
4-1 through 4-2	Original
5-1	Original
Index-1	Original

When an update is received, insert the latest changed pages and dispose of the superseded pages.

NOTE: On an update page, the changed text or table is indicated by a vertical bar in the outer margin of the page adjacent to the changed area. A changed figure is indicated by a vertical bar in the outer margin next to the figure caption. The date the update was prepared will appear beside the page number.

Safety Summary

**GENERAL
WARNINGS**

Equipment Environment

All components, whether in transportation, operation or storage, must be in a noncorrosive environment.

Electrical Shock Hazard During Maintenance

Disconnect power or take precautions to insure that contact with energized parts is avoided when servicing.

**SPECIFIC
CAUTIONS**

It is strongly recommended that cabinet power be turned off before doing any termination unit wiring. Failure to do so could result in equipment damage. Do not apply power until all wire connections are verified. Do not apply power to the termination unit when uncut dipshunts are installed. This may result in damage to the termination unit. (p. 2-11)

Sommaire de Sécurité

**AVERTISSEMENTS
D'ORDRE
GÉNÉRAL****Environnement de l'équipement**

Ne pas soumettre les composants à une atmosphère corrosive lors du transport, de l'entreposage ou l'utilisation.

Possibilité de chocs électriques durant l'entretien

Débrancher l'alimentation ou prendre les précautions pour éviter tout contact avec des composants sous tension durant l'entretien.

**ATTENTIONS
D'ORDRE
SPÉCIFIQUE**

Il est fortement recommandé de mettre l'armoire hors tension avant de procéder au câblage de la carte de raccordement afin d'éviter tout dommage matériel. Ne rétablissez pas l'alimentation avant d'avoir vérifié toutes les connexions. Ne mettez pas la carte de raccordement sous tension tant que les dipshunts ne sont pas coupés, sinon la carte de raccordement pourrait être endommagée. (p. 2-11)

Table of Contents

	<i>Page</i>
SECTION 1 - OVERVIEW	1-1
INTRODUCTION	1-1
INTENDED USER	1-1
INSTRUCTION CONTENT	1-1
HOW TO USE THIS MANUAL	1-1
GLOSSARY OF TERMS AND ABBREVIATIONS	1-2
NOMENCLATURE	1-3
REFERENCE DOCUMENTS	1-3
SPECIFICATIONS	1-4
SECTION 2 - INSTALLATION	2-1
INTRODUCTION	2-1
UNPACKING AND INSPECTION	2-1
SETUP/PHYSICAL INSTALLATION	2-1
Installing Fuses	2-1
Configuring and Installing Dipshunts	2-2
Installing the Termination Unit	2-2
Cable Connections	2-6
Cable Installation	2-7
NKTU01	2-7
NKSL01	2-8
NKSE01	2-9
NKDS01/02	2-10
NKDS03	2-10
NKCS01/02	2-11
Power Wiring	2-11
Terminal Block Wiring	2-12
CONNECTOR PINOUTS	2-13
I/O SIGNAL CONNECTIONS	2-14
SECTION 3 - MAINTENANCE	3-1
INTRODUCTION	3-1
MAINTENANCE SCHEDULE	3-1
SECTION 4 - REPAIR/REPLACEMENT PROCEDURES	4-1
INTRODUCTION	4-1
REPLACEMENT PROCEDURES	4-1
SECTION 5 - SUPPORT SERVICES	5-1
INTRODUCTION	5-1
REPLACEMENT PARTS AND ORDERING INFORMATION	5-1
TRAINING	5-1
TECHNICAL DOCUMENTATION	5-1

List of Figures

<i>No.</i>	<i>Title</i>	<i>Page</i>
2-1.	NTCS04 Termination Unit Layout	2-2
2-2.	Switching Hot vs Switching Neutral	2-5
2-3.	Termination Unit Mounting Diagram	2-5
2-4.	Multi-Function Processor Without Termination Unit and Station Cable Connections.....	2-6
2-5.	Multi-Function Processor With Termination Unit (NTMP01) Cable Connections	2-7
2-6.	Remote I/O Slave Module With Termination Unit (NTRL02/03) Cable Connections.....	2-8
2-7.	Multi-Function Controller With Termination Unit (NTMF01) Cable Connections	2-8
2-8.	Multi-Function Controller without Termination Unit (NTMF01) Cable Connections.....	2-9
2-9.	Controller Module Cable Connections	2-9
2-10.	Terminal Assignments	2-12

List of Tables

<i>No.</i>	<i>Title</i>	<i>Page</i>
1-1.	Glossary of Terms and Abbreviations	1-2
1-2.	Nomenclature	1-3
1-3.	Reference Documents	1-3
1-4.	Specifications	1-4
2-1.	Analog Input Type	2-3
2-2.	Digital Input Type.....	2-3
2-3.	Analog Input Destination for Station Feedback	2-4
2-4.	Analog Output Type.....	2-4
2-5.	P1 Pinout Connections	2-13
2-6.	P2/P3 Pinout Connections.....	2-13
2-7.	P4/P5 Pinout Connections.....	2-14
2-8.	I/O Signal Connections	2-14
3-1.	Maintenance Schedule.....	3-1
5-1.	Spare Parts List	5-1

SECTION 1 - INTRODUCTION

OVERVIEW

The Controller/Station Termination Unit (NTCS04) provides connections for control stations, digital indicator stations, and serial link connections for daisy-chaining additional NTCS02/04 or NTRL01/02/03 Termination Units. Also provided are connections for IMQRS02 and IMCIS02 Slave Modules, IMRIO02 Remote I/O Slave Modules, Controller Modules (IMCOM03/04), Quick Response Controllers (IMQRC01), Multi-Function Controllers (IMMFC03/04/05), Multi-Function Processors (IMMFP01/02), and Bailey Controls PC-90 Processors.

INTENDED USER

System engineers and technicians should read this manual before installing and operating the NTCS04 Termination Unit. DO NOT put a unit into operation until this instruction is read and understood. Refer to the table of contents or index to find specific information after the unit is operating.

INSTRUCTION CONTENT

This manual has five sections:

- | | |
|--------------------------------------|--|
| Introduction | Is an overview of the features, specifications and a description of the TCS. |
| Installation | Describes precautions to observe when handling modules, and setup procedures required before module operation. This section discusses dipshunt settings and installation procedures. |
| Maintenance | Provides a maintenance schedule. |
| Repair/Replacement Procedures | Details how to replace a TCS. |
| Support Services | Describes the support services (spare parts, training, documentation, etc.) available from Bailey Controls Company. |

HOW TO USE THIS MANUAL

Read this manual through in sequence. Read the **Section 2** thoroughly. Do the steps in order. Complete all steps in the **Section 2** before operating the TCS. Refer to the appendices for specific module and cable questions.

GLOSSARY OF TERMS AND ABBREVIATIONS

Table 1-1 lists definitions of the terms and abbreviations used in this instruction.

Table 1-1. Glossary of Terms and Abbreviations

Term	Definition
Analog	Continuously variable as opposed to discretely variable.
Bus	A channel or path for transferring data, electrical signals and power.
COM	Controller Module.
DCS	Digital Control Station. Provides monitoring and allows manipulation of a single process control loop and communicates with the MFP. It has front panel LED bar graphs that display set point, process variable and control output values.
Digital	A discretely variable signal usually having only two states, on or off.
Dipshunt	Dual in-line package with shorting straps.
DIS	Digital Indicator Station. A panel mounted device that displays information from controller, multi-function controller and multi-function processor modules.
FTP	Field Termination Panel. A panel inside the INFI 90 [®] cabinet on which to mount termination units.
MFC	Multi-Function Controller Module. A multiple-loop controller with data acquisition and information processing capabilities.
MFP	Multi-Function Processor Module. A multiple-loop controller with data acquisition and information processing capabilities.
MMU	Module Mounting Unit. A card cage that provides electrical and communication support for INFI 90/Network 90 [®] modules.
PCU	Process Control Unit. A node on the plant-wide communication network containing master and slave modules.
QRC	Quick Response Controller.
RIO	Remote I/O Slave Module.
SAC	Analog Control Station.
TU	Termination Unit. Provides input/output connection between plant equipment and the INFI 90/Network 90 modules.

[®] INFI 90 and Network 90 are registered trademarks of Elsas Bailey Process Automation.

NOMENCLATURE

Table 1-2 is a list of related hardware.

Table 1-2. Nomenclature

Nomenclature	Hardware
IEFAS01	Cabinet Mounting Hardware Kit
NTCS04	Controller/Station Termination Unit
NKTU01	Cable from NTCS04 to IMCIS02 module Cable from NTCS04 to IMCOM03/04 module Cable from NTCS04 to IMQRC01 module Cable from NTCS04 to IMQRS01/02 module
NKDS01	Cable from NTCS04 to NDCS03, NDIS01 and IISAC01 stations
NKDS02	Cable from NTCS04 to the first of multiple NDCS03, NDIS01 and IISAC01 stations
NKDS03	Interconnecting cable between multiple NDCS03, NDIS01 and IISAC01 stations
NKSL01	Cable from NTCS04 to IMMFC03/04/05 modules
NKSE01	Cable from NTCS04 to NTMF01 TU Cable from NTCS04 to another NTCS02/04 TU Cable from NTCS04 to NTMP01 TU Cable from NTCS04 to NTRL03 TU
NKCS01	Cable from NTCS04 to IISAC01, NDCS03 and NDIS01 stations
NKCS02	Cable from NTCS04 to the first of multiple IISAC01, NDCS03 and NDIS01 stations

REFERENCE DOCUMENTS

Table 1-3 lists the documents referenced in this instruction.

Table 1-3. Reference Documents

Document Number	Document
I-E93-902-1	Digital Control Station (NDCS03)
I-E93-909-3A0	I/O Power Panel (NIOP02/04)
I-E96-117	Analog Control Station (IISAC01)
I-E96-116	Digital Indicator Station (NDIS01)
I-E96-207A	Controller Modules (IMCOM03/04)
I-E96-215A	Quick Response Controller (IMQRC01)
I-E96-427A	Multi-Function Processor Termination Unit (NTMP01)
I-E96-428A	Multi-Fuction Controller Termination Unit (NTMF01)
I-E96-429A	Remote Limit Termination Unit (NTRL02/03)
I-E96-506A	Modular Power System

SPECIFICATIONS

Refer to Table 1-4 the specifications of the NTCS04 Termination Unit.

Table 1-4. Specifications

Physical Attribute/Function	Capabilities
Inputs	
4 Analog	4 to 20 mA DC
3 Digital	24 VDC or 125 VDC
Outputs	
2 Analog	1 to 5 VDC or 4 to 20 mA DC
4 Digital	24 VDC @ mA DC (isolated, open-collector type)
Surge Protection	Meets IEEE-472-1974 Surge Withstand Capability Test
Certification	CSA certified for use as process control equipment in an ordinary (nonhazardous) location.
Environmental	
Ambient Temperature	0° to 70° C (32° to 158° F)
Relative Humidity	0% to 95% up to 70° C (158° F) (noncondensing)
Altitude	Sea Level to 3 km (1.86 miles)
Air Quality	Noncorrosive
Mounting	Occupies one slot in a standard INFI 90 field termination panel.

SECTION 2 - INSTALLATION

INTRODUCTION

This section explains how to configure and install the Controller/Station Termination Unit NTCS04. Read, understand and complete the steps in the order they appear before operating the TCS. Please note that parts from the IEFAS01 Cabinet Mounting Hardware Kit are required during TCS installation.

UNPACKING AND INSPECTION

1. Examine the hardware immediately for shipping damage.
2. Notify the nearest Bailey Controls sales office of any such damage.
3. File a claim for any damage with the transportation company that handled the shipment.
4. Use the original packing material and container to store the hardware.
5. Store the hardware in an environment of good air quality, free from temperature and moisture extremes.

SETUP/PHYSICAL INSTALLATION

This section explains how to configure and install the TCS. The required procedures are fuse installation, dipshunt configuration and installation, installing the termination unit itself, cable connections and termination wiring.

Installing Fuses

Bailey Controls Company ships a 0.25 amp/250 volt fuse (Bailey P/N 1948182A32500), a 2.0 amp/250 volt fuse (Bailey P/N 1948182A32001) and two 4.0 amp/125 volt fuses (Bailey P/N 1948182A34001) with every TCS. Install the fuses as follows:

1. Install a 4.0 A fuse into fuse clip F1 and F3 (See Figure 2-1 for fuse clip locations).
2. Install the 2.0 A fuse into fuse clip F2.
3. Install the 0.25 A fuse into fuse clip F4.

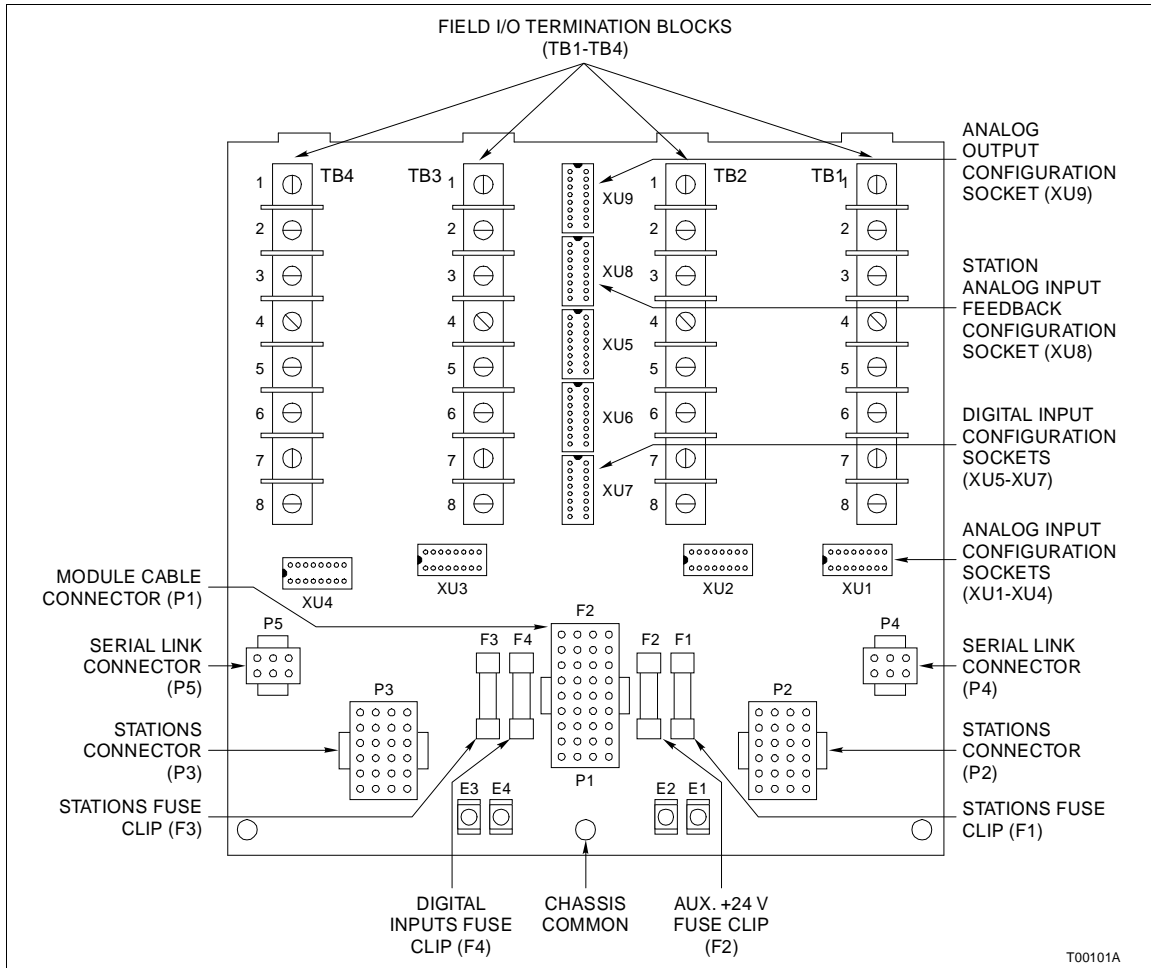

Figure 2-1. NTCS04 Termination Unit Layout

Configuring and Installing Dipshunts

Configure a dipshunt by either cutting straps or leaving straps uncut in certain sequences. Cut the dipshunt straps using a standard shunt cutting tool (Amp Inc. #435862-1). Always cut straps completely and ensure they do not touch adjacent straps. Install the configured dipshunt into the desired socket (XU1 through XU9) on the TCS circuit board. Please note that in some instances (XU9) not installing a dipshunt establishes a configuration. To install a dipshunt, align the end of the dipshunt identified with the silver dot to the end of the socket having an identification mark and push the dipshunt into the socket. Be careful not to bend any pins during insertion. Tables 2-1, 2-2, 2-3, and 2-4 show the dipshunt configuration sequences and corresponding application for each socket location.

Installing the Termination Unit

1. Insert the tabs of the circuit board into the proper slots of the field termination panel standoff (See Figure 2-3) and slide the circuit board into position.

Table 2-1. Analog Input Type

Analog Input	
Application/ Signal Type	Dipshunt Configuration XU1 - XU4
System Powered 4 - 20 mA	
Externally Powered 4 - 20 mA	
Single Ended Voltage	
Differential Voltage	

T00033A

Table 2-2. Digital Input Type

Digital Input	
Application/ Signal Type	Dipshunt Configuration XU5 - XU7
System Powered E3/E4	
Field Powered ¹	

T00702A

NOTE: 1. Using the field device to complete the path to ground is commonly referred to as **switching neutral**. Using the field device to complete the path to the slave is referred to as **switching hot**. If **switching hot** is the desired method, the field powered dipshunt configuration must be used. If system power is required, it should be wired as a field source. See Figure 2-2 for an example of **switching hot** and **switching neutral**.

Table 2-3. Analog Input Destination for Station Feedback

Analog Input (with Station Feedback)	
Application/ Signal Type	Dipshunt Configuration XU8
Station No. 1 (P2 Connector)	
Station No. 2 (P3 Connector)	<p style="text-align: right;">T00703A</p>

Table 2-4. Analog Output Type

Analog Output	
Application/ Signal Type	Dipshunt Configuration XU9
Both Oupts in Voltage Mode	
Output 1 in Voltage Mode, Output 2 in Current Mode	
Output 1 in Current Mode, Output 2 in Voltage Mode	
Both Outputs in Current Mode (No Dipshunt Required)	<p style="text-align: right;">T00035A</p>

2. Secure the termination unit circuit board to the field termination panel with two screws from the IEFAS01 Cabinet Mounting Hardware Kit (See Figure 2-3).
3. Install a screw (from the IEFAS01 Cabinet Mounting Hardware Kit) for the chassis common connection.

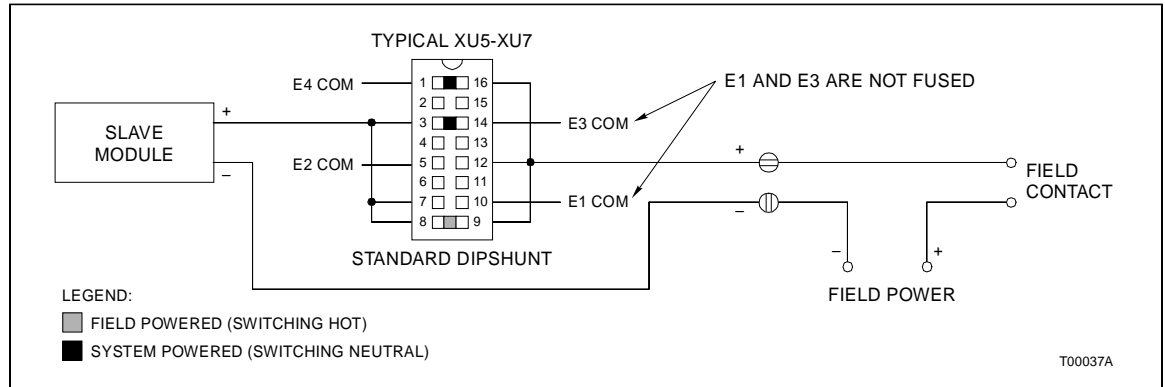

Figure 2-2. Switching Hot vs Switching Neutral

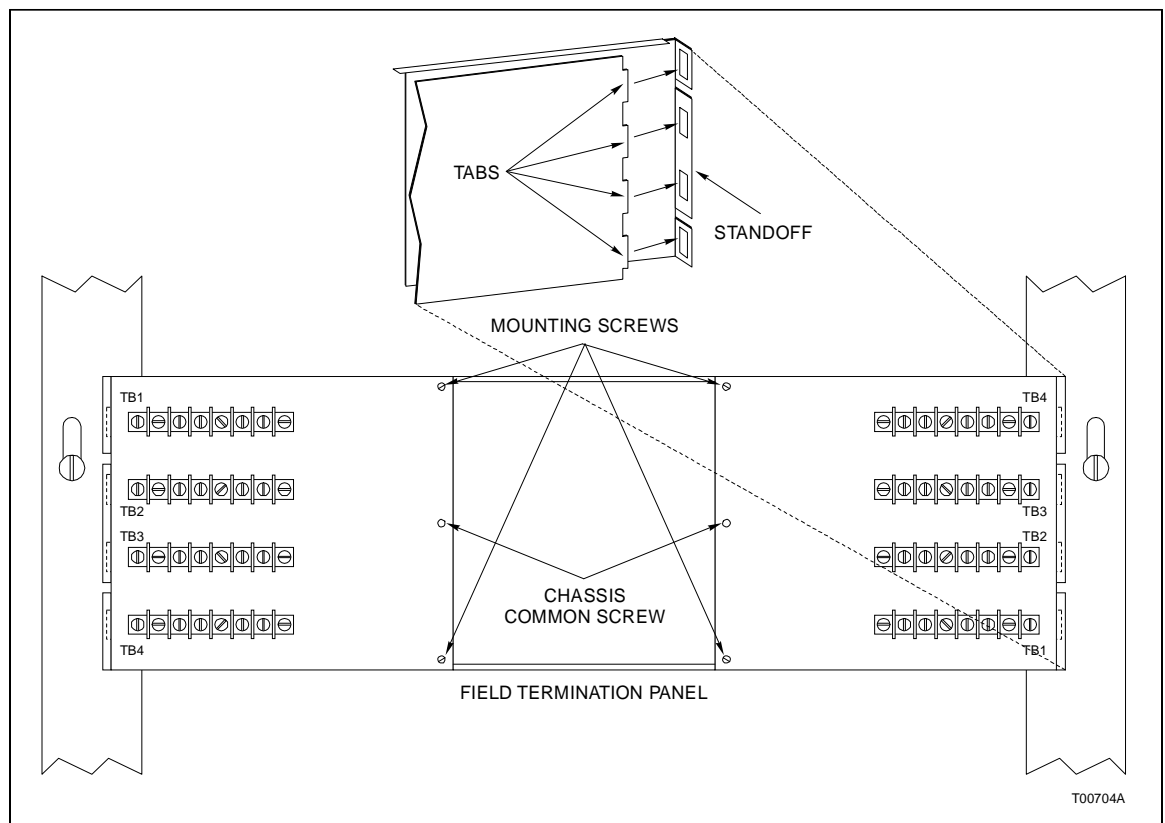

Figure 2-3. Termination Unit Mounting Diagram

Cable Connections

The Controller/Station Termination Unit (NTCS04) can be set up for several different applications. These include applications with or without control and indicator stations. The TCS terminates analog and digital I/O signals and interfaces them directly to a master/slave module. Figures 2-4 through 2-9 show the cables to use and the cable connections for several different applications of the TCS. See Figure 2-1 for the location of cable connectors P1 through P5.

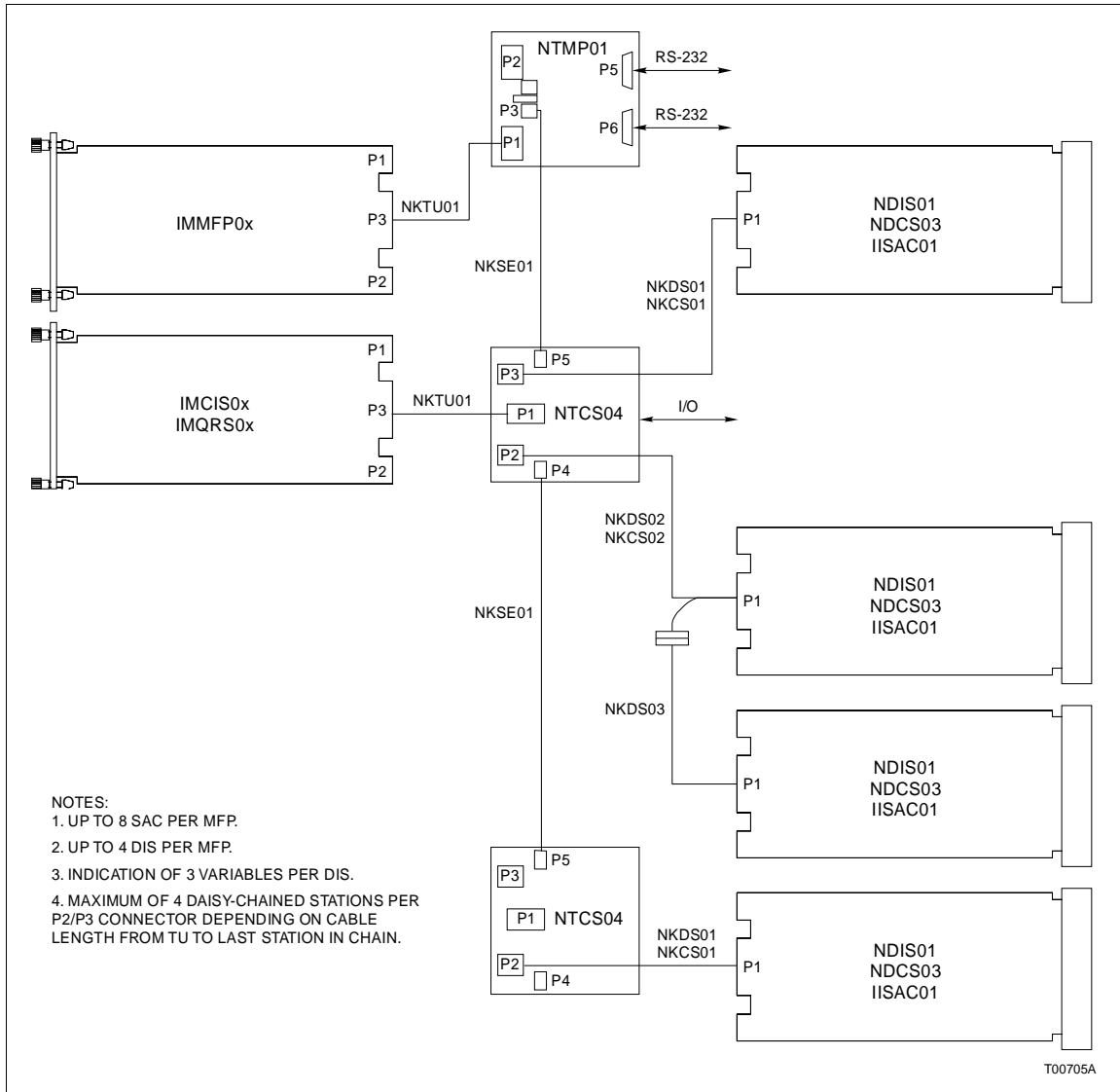

Figure 2-4. Multi-Function Processor Without Termination Unit and Station Cable Connections

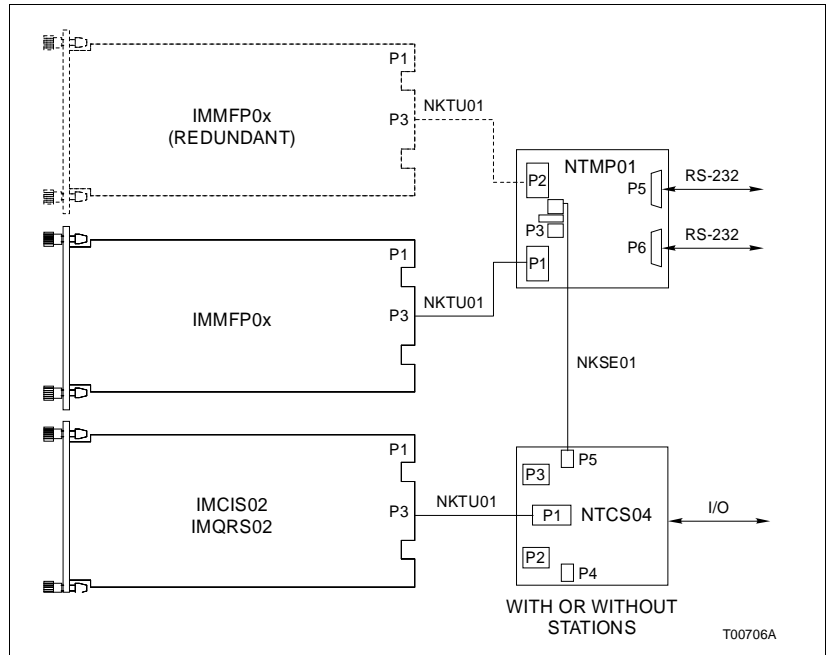

Figure 2-5. Multi-Function Processor With Termination Unit (NTMP01) Cable Connections

Cable Installation

NOTE: Properly mount the TCS on the field termination panel BEFORE installing cables.

NKTU01

This cable connects the TCS to a master/slave module. To install the TU cable:

1. Insert the hooded end of the cable into the module mounting unit backplane slot assigned to the master/slave module. The cable should latch securely in place. Card edge connector P3 of the master/slave module connects to this end of the cable.
2. Insert the male 36 pin connector end of the cable into the P1 connector of the TCS. The cable should latch securely in place.

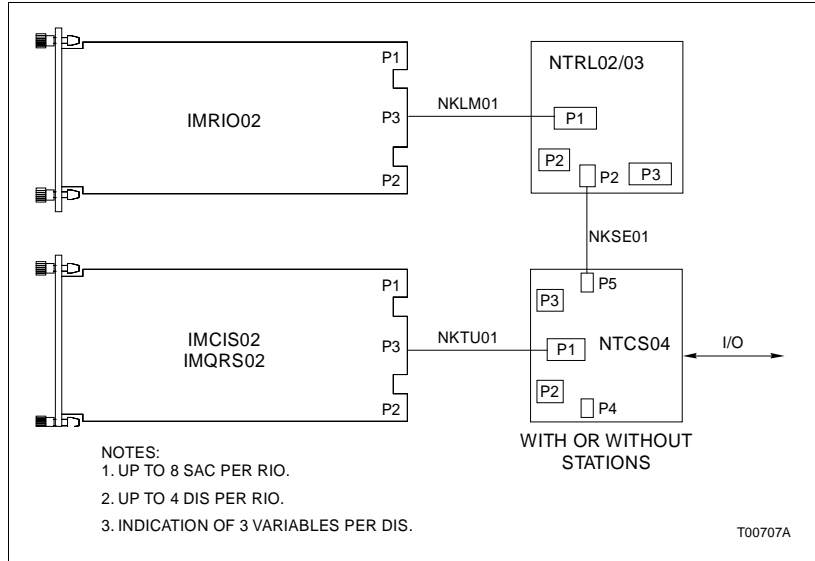

Figure 2-6. Remote I/O Slave Module With Termination Unit (NTRLO2/03) Cable Connections

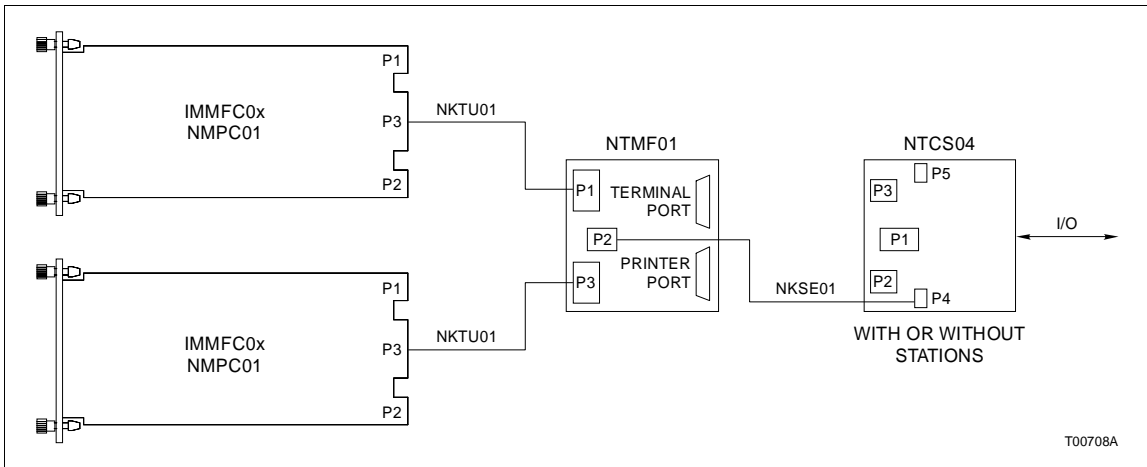

Figure 2-7. Multi-Function Controller With Termination Unit (NTMF01) Cable Connections

NKSL01

This cable extends the MFC serial link to a TCS. It provides a communication path between the MFC and stations connected to the TCS. It connects directly to the TCS and is used only

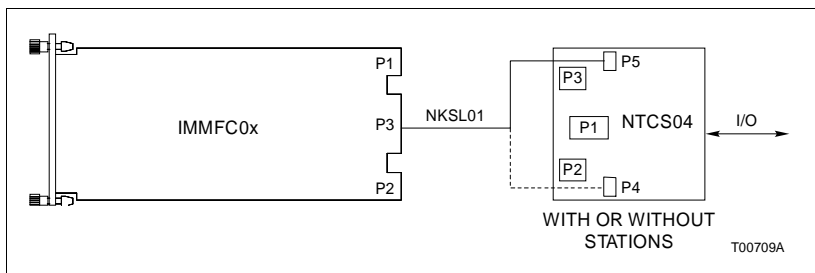

Figure 2-8. Multi-Function Controller without Termination Unit (NTMF01) Cable Connections

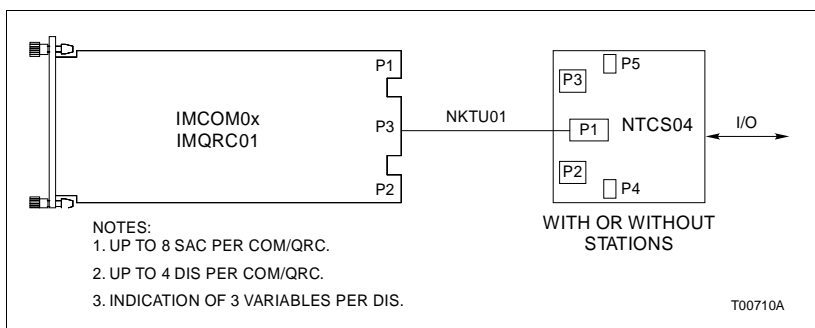

Figure 2-9. Controller Module Cable Connections

when a MFC Termination Unit (NTMF01) is not used. To install the serial link cable:

1. Insert the hooded end of the cable into the module mounting unit backplane slot assigned to the MFC module. The cable should latch securely in place. Card edge connector P3 of the MFC module connects to this end of the cable.
2. Insert the male six pin connector end of the cable into the P4/P5 connector of the TCS. The cable should latch securely in place.

NKSE01

This cable extends the MFP/MFC serial link from NTMP01, NTMF01 or NTRL02/03 termination units to a TCS. It also extends the serial link from one TCS (with or without stations) to another. To install the serial extension cable:

1. Insert one end of the cable into the P2 connector of the NTMF01/NTRL02/03 TU, the P3/P4 connector of the NTMP01 TU or the P4/P5 connector of the TCS (TCS to TCS application). The cable should latch securely in place.

2. Insert the other end of the cable into the P4/P5 connector of the TCS. The cable should latch securely into place.

NKDS01/02

The NKDS01 cable connects the TCS to a single NDIS01, NDCS03, or IISAC01 station. It provides a signal path for the serial link, I/O signals, and control signals used by the station for monitoring and control functions. The NKDS02 cable connects the first of multiple NDIS01, NDCS03 and IISAC01 stations to the TCS. To install the station cable:

NOTE: These cables provide connection for only one analog input signal to the station.

1. Remove the NDIS01, NDCS03 or IISAC01 station from the station housing.
2. Insert the hooded end into the station housing backplane. Viewing the housing from the back, the cable inserts into the right slot. The cable should latch securely into place. Card edge connector P1 of the station circuit board connects to this end of the cable.
3. Insert the male 24 pin connector end of the cable into the P2/P3 connector of the TCS. The cable should latch securely into place.
4. Reinstall the NDIS01, NDCS03 or IISAC01 station into the station housing.

NKDS03

This cable interconnects multiple NDCS03, NDIS01 and IISAC01 stations. Install the cable as follows:

1. Remove the NDIS01, NDCS03 or IISAC01 station from the station housing.
2. Insert the hooded end of the cable into the station housing backplane. Viewing the station from the back, the cable inserts into the right slot. The cable should latch securely into place. Card edge connector P1 of the station circuit board connects to this end of the cable.
3. Insert the male six pin connector end of the cable into the female six pin connector end of the NKDS02/NKCS02 (when connecting the second of multiple stations) or NKDS03 (when connecting three or more stations) cable. The cable should latch securely into place.
4. Reinstall the NDIS01, NDCS03 or IISAC01 station into the station housing.

NKCS01/02

These cables function and install in the same manner as the NKDS01/02 cables. The NKCS01 cable connects the TCS to a single NDIS01, NDCS03 or IISAC01 station. The NKCS02 cable connects the first of multiple NDIS01, NDCS03 or IISAC01 stations to the TCS. To install the station cable:

NOTE: These cables provide connection for two analog input signals to a station and enable full utilization of IISAC01 stations. These cables can be used to connect NDIS01 and NDCS03 stations even though they use only one analog input signal.

1. Remove the NDIS01, NDCS03 or IISAC01 station from the station housing.
2. Insert the hooded end into the station housing backplane. Viewing the housing from the back, the cable inserts into the right slot. The cable should latch securely into place. Card edge connector P1 of the station circuit board connects to this end of the cable.
3. Insert the male 24 pin connector end of the cable into the P2/P3 connector of the TCS. The cable should latch securely into place.
4. Reinstall the NDIS01, NDCS03 or IISAC01 station into the station housing.

Power Wiring

CAUTION	It is strongly recommended that cabinet power be turned off before doing any termination unit wiring. Failure to do so could result in equipment damage. Do not apply power until all wire connections are verified. Do not apply power to the termination unit when uncut dipshunts are installed. This may result in damage to the termination unit.
ATTENTION	Il est fortement recommandé de mettre l'armoire hors tension avant de procéder au câblage de la carte de raccordement afin d'éviter tout dommage matériel. Ne rétablissez pas l'alimentation avant d'avoir vérifié toutes les connexions. Ne mettez pas la carte de raccordement sous tension tant que les dipshunts ne sont pas coupés, sinon la carte de raccordement pourrait être endommagée.

There are four terminals that provide power and ground connections. See Figure 2-1 for terminal locations. Terminal E1 is the +24 VDC power connection. Terminals E2 and E4 are I/O common grounds. Terminal E3 is for +24 VDC or +125 VDC digital input power. The power source connected to Terminal E3 depends on the digital input logic, signal level required. A

chassis ground point is on the edge of the circuit board next to the P1 plug. Install a screw into the chassis common point. This will connect the NTCS04 termination unit to the chassis ground point of the NFTP01 Field Termination Panel. Refer to the following steps when installing the TCS into a modular power supply system.

1. Attach a 14 AWG wire from the +24 VDC power distribution source to the E1 terminal on the TCS.
2. Attach one 14 AWG wire from the I/O common to the E2 terminal of the TCS.
3. Attach a 14 AWG wire from the I/O common to the E4 terminal of the TCS.
4. Attach a 14 AWG wire from the +24 VDC power distribution source or the +125 VDC auxiliary power distribution source to the E3 terminal of the TCS.

Refer to the **Modular Power System Product Instruction Manual** for further details.

Terminal Block Wiring

Refer to Figure 2-10 for TCS terminal block assignments and wiring polarity. Field wiring should be 12 to 22 AWG wire. Digital I/O lines should be twisted pairs of multi-stranded wire with low leakage insulation. The input lines should be shielded, although it is generally not necessary for each pair of wires to be separately shielded. The shields should be grounded to the chassis common. The twisted pairs of input lines must not be in the same conduit with lines carrying either

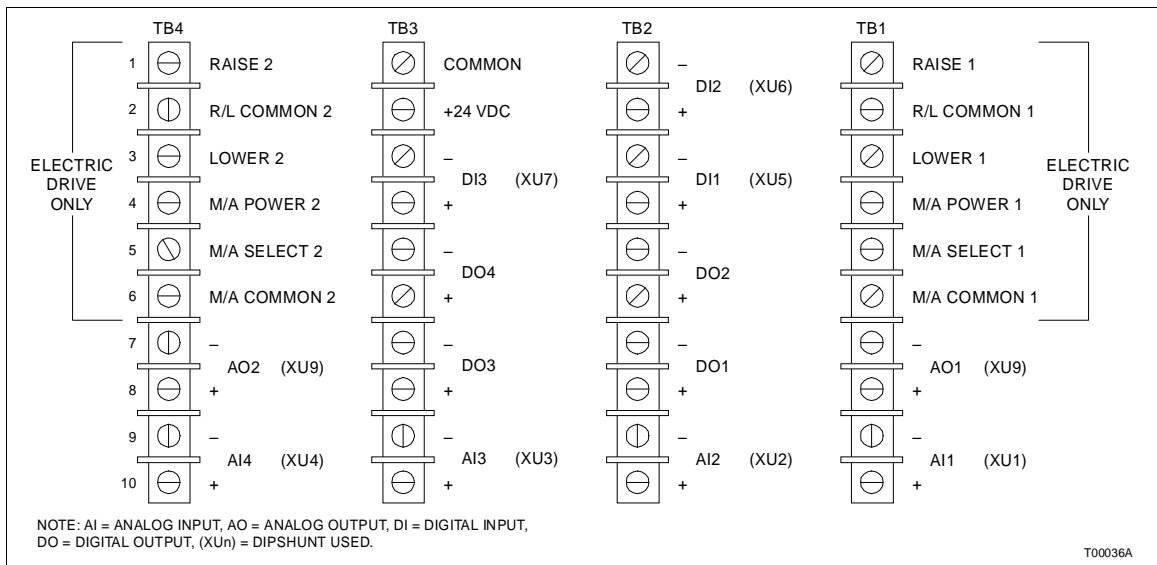

Figure 2-10. Terminal Assignments

AC voltages or switched outputs (such as those from digital output relays) greater than 50 volt-amps DC. Please note that Terminals TB3-1 and TB3-2 are auxiliary +24 VDC power connections. They can be connected to digital output terminals only and are fused.

NOTE: Proper wiring polarity is required for DC voltage signals.

CONNECTOR PINOUTS

Refer to Table 2-5 for P1 pinout connections, and to Table 2-6 for P2 and P3 pinout connections.

Table 2-5. P1 Pinout Connections

Pin	Signal	Pin	Signal	Pin	Signal
1	DO1-	7	DO4-	25	AO1-
2	DO1+	8	DO4+	26	AO1+
3	DO2-	9	NC	27	AO2-
4	DO2+	10	NC	28	AO2+
5	DO3-	11	NC	29	AI1-
6	DO3+	12	NC	30	AI1+
13	SL-	19	DI2-	31	AI2-
14	SHIELDS	20	DI2+	32	AI2+
15	NC	21	DI3-	33	AI3-
16	SL+	22	DI3+	34	AI3+
17	DI1-	23	+24 VDC	35	AI4-
18	DI1+	24	COM	36	AI4+

NOTE: DO=Digital Output, DI=Digital Input, AI=Analog Input, AO=Analog Output, SL=Serial Link,NC=Not Connected

Table 2-6. P2/P3 Pinout Connections

Pin	Signal	Pin	Signal
1	Serial Link (-)	13	M/A Common
2	Serial Link (+)	14	M/A Select
3	+24 VDC	15	R/L Common
4	Supply Common	16	Raise
5	M/A Power	17	R/L Common
6	M/A Common	18	Lower
7	Analog Output (-) ¹	19	Analog Input (-) ³
8	Analog Output (+) ¹	20	Analog Input (+) ³
9	Analog Load (-)	21	NC
10	Analog Load (+)	22	NC
11	Analog Input (-) ²	23	NC
12	Analog Input (+) ²	24	Cable Shield

NOTES:

1. Connected to analog output 1 for P2, analog output 2 for P3.
2. Connected to analog input 3 for P2, analog input 4 for P3.
3. Connected to analog input 1 for P2, analog input 2 for P3.

Table 2-7. P4/P5 Pinout Connections

Pin	Signal	Pin	Signal
1	Serial Link (-)	4	NC
2	Serial Link (+)	5	NC
3	NC	6	Chassis Common

NOTE: NC = Not Connected

I/O SIGNAL CONNECTIONS

Table 2-8 shows the cable pin connections from the P3 connection of a master/slave to the P1 connection of the TCS.

Table 2-8. I/O Signal Connections

NKTU01		NKTU01	
1 3 P P12		1 3 P P12	
1 -----1	J -----22		
A -----2	9 -----23		
2 -----3	K -----24		
B -----4	10 -----25		
3 -----5	L -----26		
C -----6	11 -----27		
4 -----7	M -----28		
D -----8	12 -----29		
5 -----13	N -----30		
E -----16	13 -----31		
6 -----17	P -----32		
F -----18	14 -----33		
7 -----19	R -----34		
H -----20	15 -----35		
8 -----21	S -----36		

NOTES:

1. P3 on slave or controller module (letters on component side of circuit board, numbers on solder side of circuit board).
2. P1 on NTCS04.

SECTION 3 - MAINTENANCE

INTRODUCTION

The Control I/O Termination Unit requires limited maintenance. This section contains a maintenance schedule.

MAINTENANCE SCHEDULE

Execute the tasks in Table 3-1 at the specified intervals.

Table 3-1. Maintenance Schedule

Task	Interval
Clean and tighten all power and grounding connections	Every 6 months or during plant shut-down, whichever occurs first.
Use a static safe vacuum cleaner to remove dust from: Modules Module Mounting Unit Fan Assembly Power Entry Panel Termination Units/Modules	Every 6 months or during plant shut-down, whichever occurs first.

SECTION 4 - REPAIR/REPLACEMENT PROCEDURES

INTRODUCTION

This section explains the replacement procedures for the controller/station termination unit. The tools required to replace a TCS are:

- Flat head screwdriver.
- Cross head screwdriver.
- IC chip puller.
- Shunt cutting tool (AMP PN 435862-1).

REPLACEMENT PROCEDURES

If a TCS is faulty, replace it with a new one. DO NOT try to repair the module. Replacing components may affect performance and certification. To replace a TCS termination unit:

1. Turn OFF the INFI 90 cabinet power.

NOTE: The I/O power supplies providing the power to the TU may not be located in the same cabinet as the TU. Make sure you turn OFF the cabinet supplying the power.

2. Label and remove all field wiring from the terminal blocks (TB1 through TB4).
3. Label and disconnect all cables connected to the TCS (P1 through P5).
4. Label and disconnect system I/O power and ground from the E1 through E4 terminals.
5. Remove the two screws securing the TCS to the field termination panel and the chassis common screw and slide out the TCS.
6. Remove the dipshunts from the old TCS and place them into the new one, or configure and install new dipshunts. Refer to [Section 2](#) for details on configuring dipshunts.
7. Install fuses into the fuse clips. Refer to [Section 2](#) for details on fuse installation.
8. Insert the tabs of the circuit board into the proper slots of the field termination panel standoff and slide the circuit board into position.

9. Secure the termination unit circuit board to the field termination panel with two screws.
10. Install the chassis common screw.
11. Reconnect all field wiring removed in step 2.
12. Reconnect the system I/O power wires and system ground wires removed in step 3.
13. Reconnect all cables removed in step 4.
14. Verify proper connections to the TCS.
15. Energize the cabinet power supply that provides power to the TCS.

SECTION 5 - SUPPORT SERVICES

INTRODUCTION

Bailey Controls Company is ready to help in the use, application and repair of its products. Contact the nearest sales office to make requests for sales, applications, installation, repair, overhaul and maintenance contract services.

REPLACEMENT PARTS AND ORDERING INFORMATION

When making repairs, order replacement parts from a Bailey Controls sales office. Provide this information:

1. Part description, part number and quantity.
2. Model and serial numbers (if applicable).
3. Bailey Controls instruction manual number, page number and reference figure that identifies the part.

Order parts without commercial descriptions from the nearest Bailey Controls Company sales office.

Table 5-1. Spare Parts List

Description	Component	Part No.
Dipshunt (16 pin)	XU1 - XU9	1946715A8
Fuse 4.0 A/125 VDC Slow, 5 mm x 20 mm	F1, F3	1948182A34001
Fuse 2.0 A/250 VDC Slow, 5 mm x 20 mm	F2	1948182A32001
Fuse 0.25 A/250 VDC Slow, 5 mm x 20 mm	F4	1948182A32500
Cabinet Mounting Hardware Kit	Screws	IEFAS01

TRAINING

Bailey Controls Company has a modern training facility that provides service and repair instruction. This facility is available for in-plant training of personnel. Contact a Bailey Controls sales office for specific information and scheduling.

TECHNICAL DOCUMENTATION

Additional copies of this manual or other Bailey Controls manuals, can be obtained from the nearest Bailey Controls sales office at a reasonable charge.

Index

C
Cables 1-3, 2-6, 2-7

D
Dipshunts 2-2, 5-1

F
Fuses 2-1, 5-1

G
Glossary 1-2

H
How to use this manual 1-1

I
I/O wiring 2-12
Installation 2-1
Instruction content 1-1
Intended user 1-1

M
Maintenance schedule 3-1

O
Overview 1-1

R
References 1-3
Related equipment 1-3
Replacement parts/ordering information 5-1
Replacement procedures 4-1

S
Setup 2-1
Spare parts 5-1
Specifications 1-4

T
Technical documentation 5-1
Training 5-1

U
Unpacking and inspection 2-1

Visit *Elsag Bailey* on the World Wide Web at <http://www.bailey.com>

Our worldwide staff of professionals is ready to meet *your* needs for process automation.
For the location nearest you, please contact the appropriate regional office.

AMERICAS

29801 Euclid Avenue
Wickliffe, Ohio USA 44092
Telephone 1-216-585-8500
Telefax 1-216-585-8756

ASIA/PACIFIC

152 Beach Road
Gateway East #20-04
Singapore 189721
Telephone 65-391-0800
Telefax 65-292-9011

EUROPE, AFRICA, MIDDLE EAST

Via Puccini 2
16154 Genoa, Italy
Telephone 39-10-6582-943
Telefax 39-10-6582-941

GERMANY

Graefstrasse 97
D-60487 Frankfurt Main
Germany
Telephone 49-69-799-0
Telefax 49-69-799-2406